



FERBER TRUCKS PRODUCT RANGE

GLOBAL LOGISTIC SOLUTIONS

In textiles, paper, plastic film, metal packaging facilities - Tessile, carta, film plastici, imballaggi

In Textil-, Papier-, Kunststofffolie- und Metallverpackungsanlagen

Dans l'industrie du textile, papier, film plastique, emballage métallique

En el sector textil, papel, película de plástico, equipos de envasado de metal

Na indústria têxtil, papel, filme plástico, equipamentos de embalagem de metal

Tekstil, kağıt, plastik film, metal ambalaj tesislerinde

Текстиль, бумага, полиэтиленовая пленка, упаковка

نداعمل في ل غتلا و ةئب عتلا قفارمو ،مل يف كئيتس ال بل او ق رولا و تاج و س ن مل ل اجم يف

Some trucks in FERBER product range

Alcuni carrelli della gamma FERBER

Einige Wagen in der FERBER-Produktionspalette

Ürün yelpazesindeki bazı arabalar

устройства для транспортировки внутри текстильных подразделений

Certains charriots de la gamme de produits FERBER

Algunas carretillas en la gama de productos FERBER

Na gama de produtos FERBER, alguns carrinhos

تاجت ن م ةعوم جم يف تان حاشلا ضعب







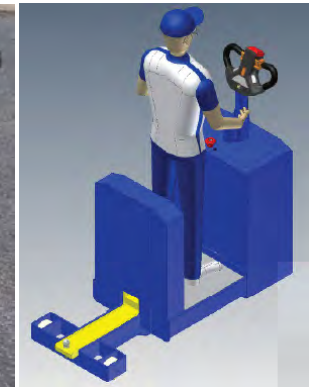

Transporting and inserting drawn-in full warp beams, take-up of fabric rolls from FERBER batchers
 Trasporto e carico/scarico subbi su macchine tessili – presa e trasporto rotoli di tessuto da avvolgitori FERBER
 Transportieren und Einlegen von eingezogenen Vollkettbäumen. - Dockenübernahme vom FERBER-Dockenwickler
 Transport et chargement / déchargement d'ensouples - Transport et chargement / déchargement de rouleaux de tissu
 Transporte y carga/ descarga vigas de máquina textil - Transporte y carga/ descarga rollos de tela
 Indústria Têxtil - Transporte, carga / descarga de orgãos – Transporte, carga / descarga de rolos de tecido
 Taharlanmış dolu leventlerin taşınması ve dokuma makinesine bindirilmesi, kumaş rulolarının FERBER sarıcıdan alınması
 устройства для транспортировки внутри текстильных подразделений
 قۇدايىنىڭ نام شامقۇل تاقىل تاقىلدا خىتا ، لىم كە ھوشىت مزىحلا يىف لىدا خىتا لىدا خىتا
 Looms-Telai-Webmaschinen : DORNIER, ITEMA, PANTER, PICAÑOL , SMIT, SULZER, TOYODA, TRINCA, TSUDAKOMA

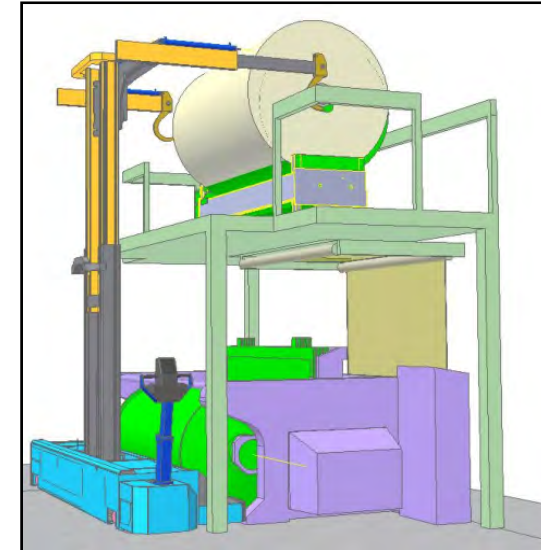
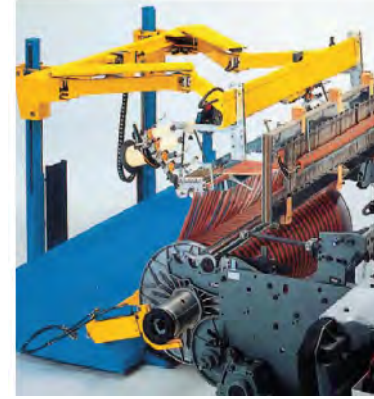
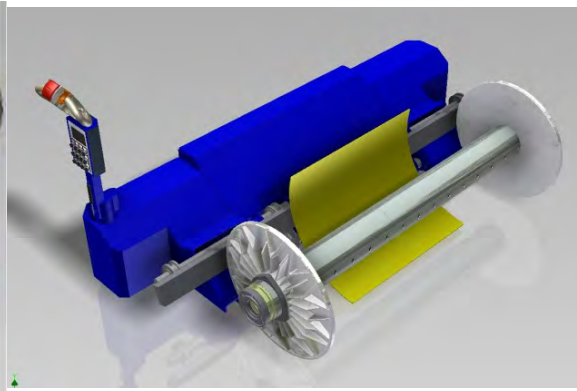
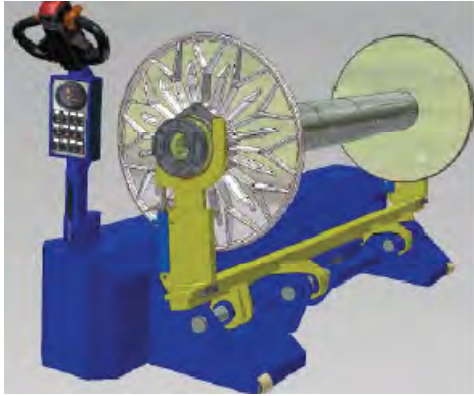



ETG500 QSC



CR29 with harness mounting device

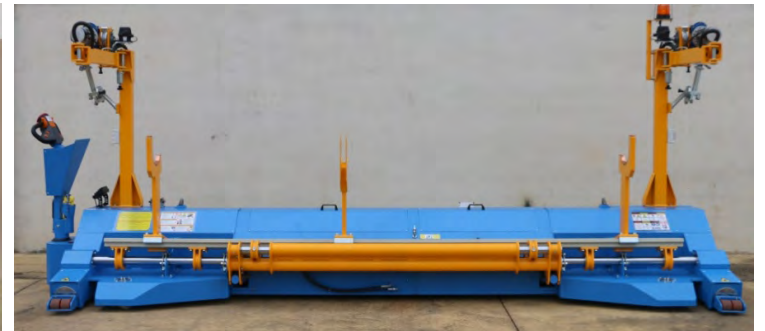

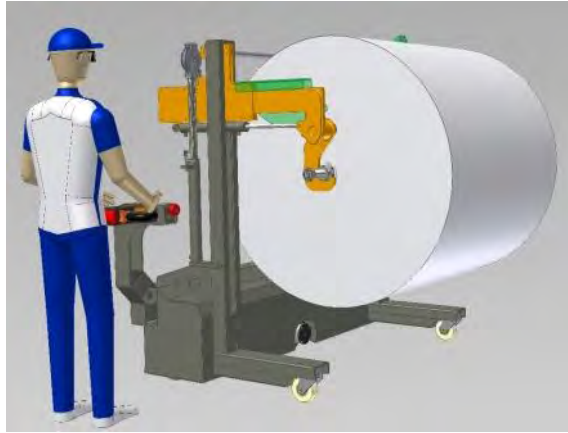

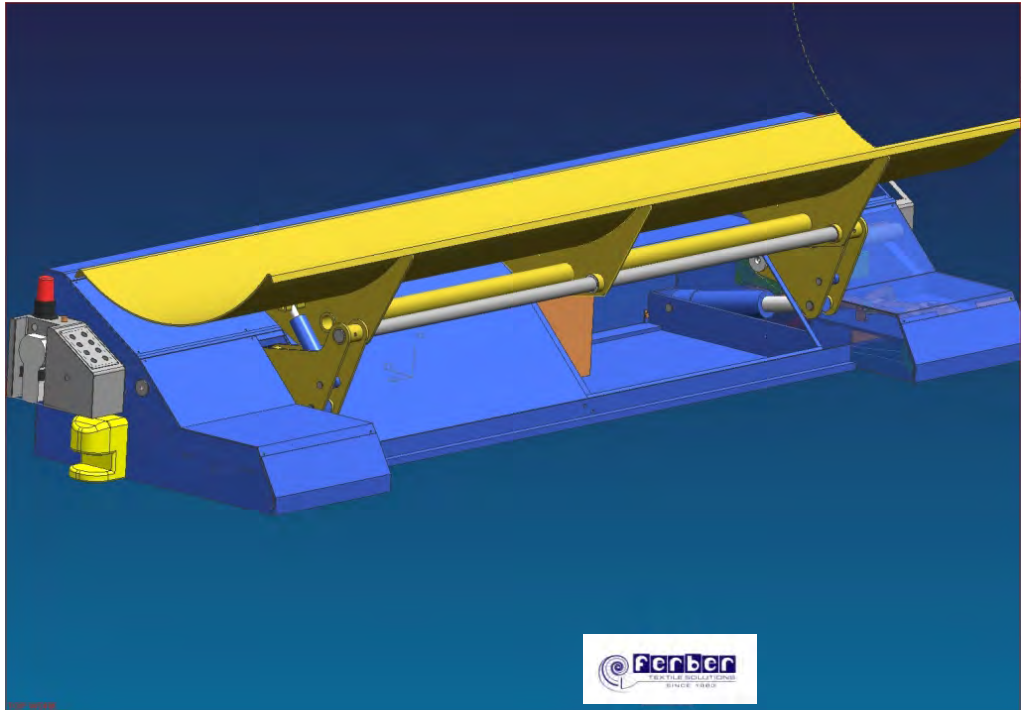

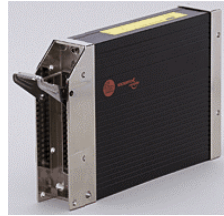

Changement rapide complet
sur métiers double ensouple
(secteurs pour chemises et
tissus d'ameublement)

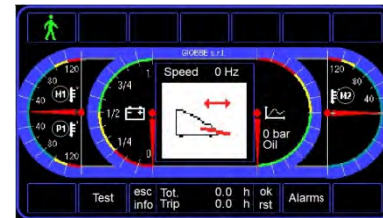
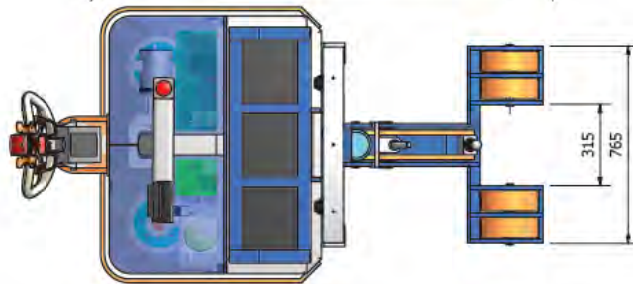
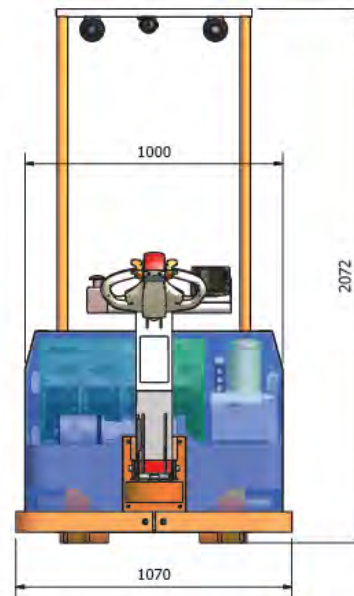
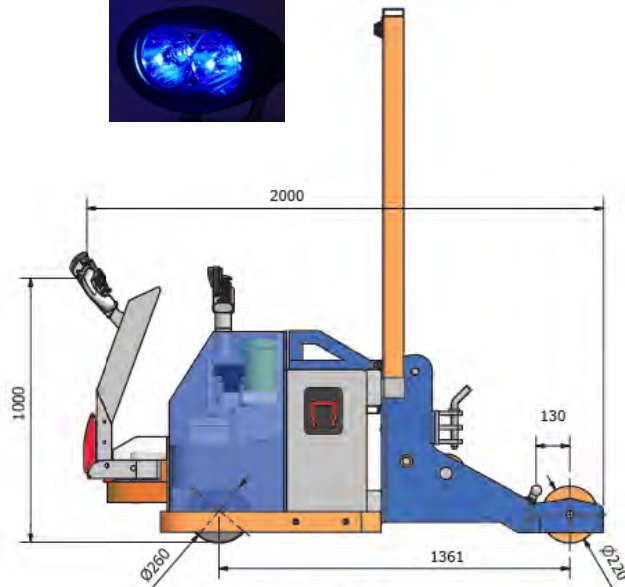

Easy style change with high efficiency on PICAÑOL SPLIT FLANGE LOOMS
Cambio artículo "QSC" ad alta efficienza per telai PICAÑOL "SPLIT FLANGE"
Einfacher Artikelwechsel mit hoher -Effizienz auf PICAÑOL "SPLIT FLANGE"-Textilmaschinen
Changement rapide d'article "QSC" haute efficacité pour les métiers à tisser PICAÑOL
Fácil cambio de estilo " QSC " con una alta eficiencia en telar PICAÑOL "SPLIT FLANGE"
Mudança fácil de artigo "QSC" com alta eficiência para tear PICAÑOL "SPLIT FLANGE"
PICAÑOL SPLIT FLANŞ tipi tezgahlarda kolay tip deęişimi ve yüksek verimlilik
Легкая смена стилия с высокой эффеkтивностью на PICAÑOL маячит
PICAÑOL جيسننلاو لزغل تالآ ىلع ةيلاع ةءافكب لهسلا هبولسأ ريغت

Single beam version - Versione singolo subbio - Version simple ensouple - Versión con plegador estándar

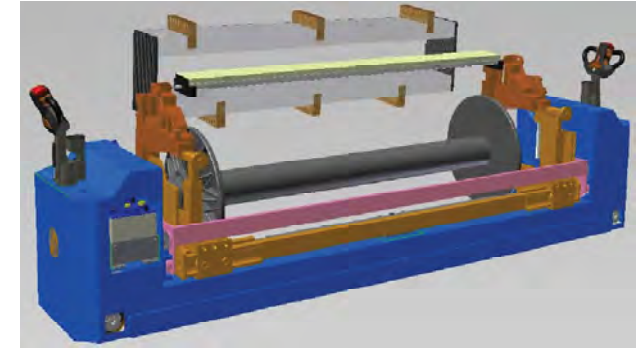
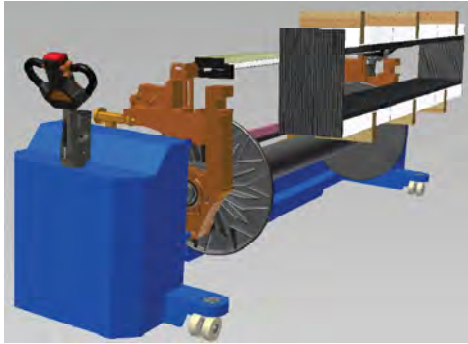

Double beams version - Versione doppio subbio - Version double ensouple - Versión con dos plegadores



Transporting and inserting warp beams on warp knitting machines-**Trasporto e carico/scarico subbi su macchine Raschel**
 Transportieren und Einlegen von eingezogenen Vollkettbäumen von Kettenwirkmaschinen
Transport et chargement/déchargement d'ensouples Raschel Transporte y carga / descarga vigas de máquina textil Raschel
 Transporte e carga / descarga orgãos - KarlMayer-Liba -Çözgülü örme makinelerinde çözgü leventlerinin taşınması ve bindirilmesi
 Транспортировка и вставки навоев на вязальных машинах основы يولت ةكاي حل تال آى ل ع جاجوع ال مزحل ل اءءءو ل ق

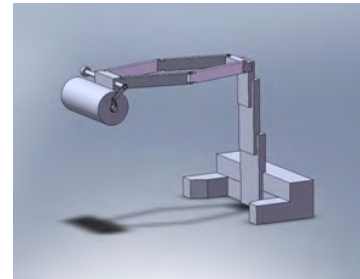

LOGISTICS ON WARP KNITTING MACHINES LOGISTICA PER TESSUTO-NON-TESSUTO
LOGISTIK AUF KETTENWIRKMASCHINEN LOGISTIQUE pour METIERS A TRICOTER RECTILIGNES LOGÍSTICA PARA MÁQUINAS RETILINEAS DE PUNTO LOGÍSTICA PARA MÁQUINAS DE TRICOTAR ÇÖZGÜLÜ ÖRME MAKİNELERİ LOJİSTİĞİ
РАШЕЛЬ ТИП ВЯЗАЛЬНЫЕ МАШИНЫ
 ةكاي حل تال آ هوش ت ةي تس ج و ل ل ا ت اءءءو ل ا

Transporting and inserting warp beams on VAN DE WIELE textile machines
Trasporto e carico/scarico subbi telai VAN DE WIELE - Transportieren und Einlegen von eingezogenen VAN DE WIELE-Vollkettbäumen
Transport et chargement déchargement d'ensouples pour métiers VAN DE WIELE
Transporte y carga / descarga vigas de máquina textil VAN DE WIELE - Transporte e carga / descarga orgãos teares VAN DE WIELE
Çözgü leventlerinin VAN DE WIELE MAKİNELERİNE taşınması ve bindirilmesi
VAN DE WIELE тип текстильные машины
جيسن لاول لزغلا تالآ ىلع جاجوع الاز مزحل لاخداو لقن VAN DE WIELE

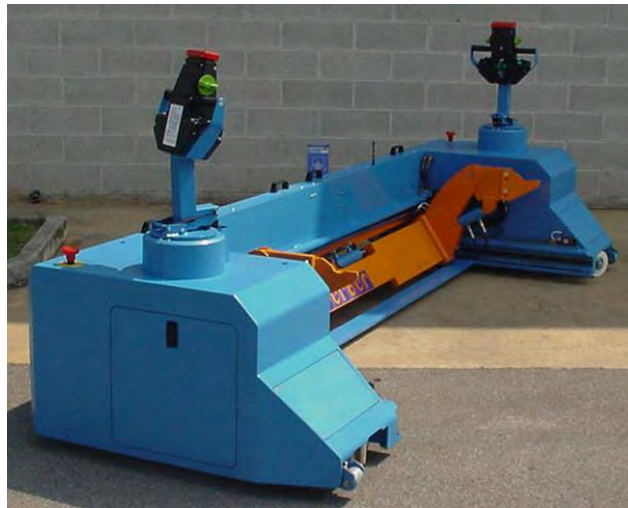

Special trucks - speciali-Spezialwagen-Chariots spéciaux-Carretillas especiales-Carrinhos especiais-Özel imalatlar -специальные - قصاڤ تالآ

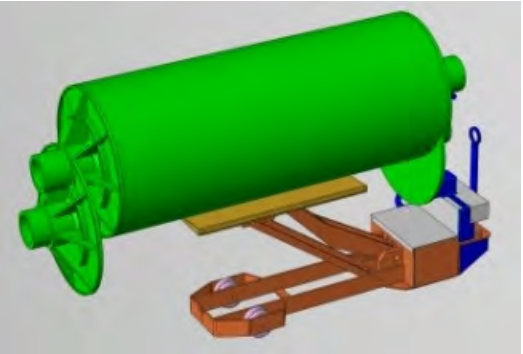

Certains chariots peuvent également charger/décharger le magasin de stockage type carrousel de Ferber avec système de rayonnage. Stockage et manutention pour une large gamme de produits, y compris ensouples. Rouleaux, bobines, fûts et produits longs

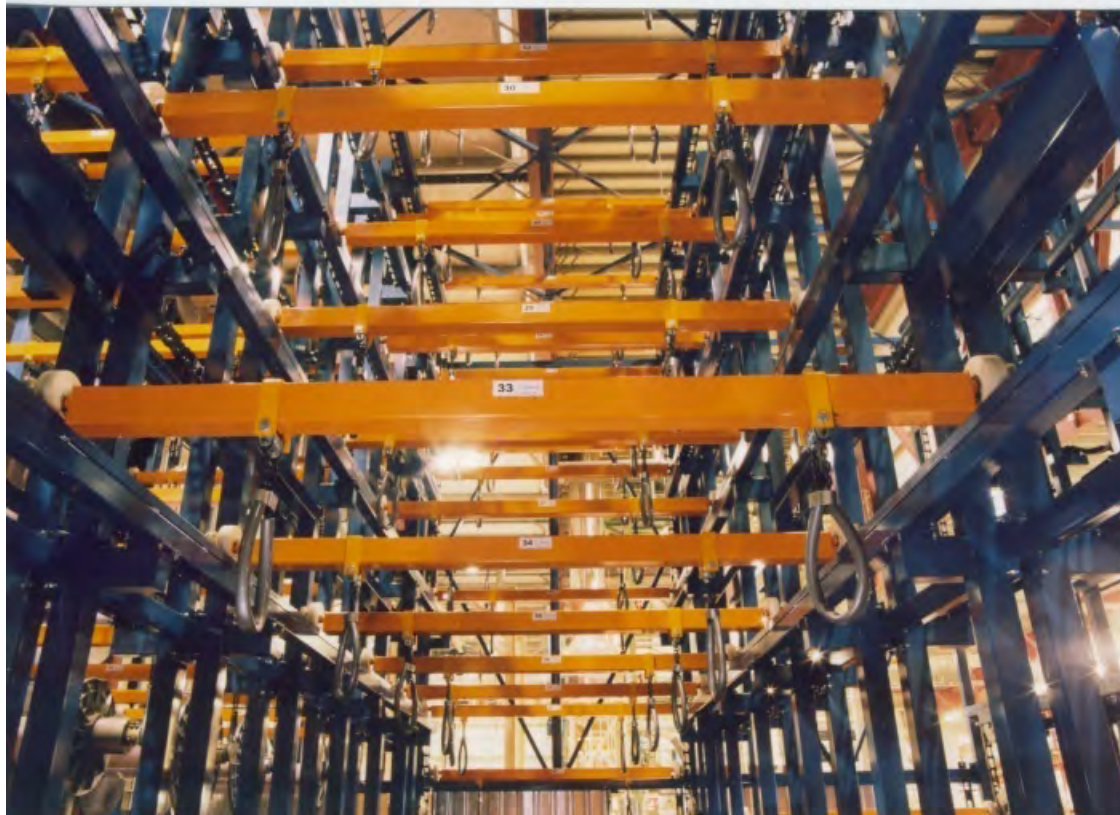

FIVE YEARS WARRANTY
ON ALL ELECTRONIC COMPONENTS



Warping Beams – Subbi ordito – Kettbäume - Ensouples - Plegadores – Orgãos de urdidura
Çözgü leventleri - Хабоее - جيس نلا هوشت مرزحلا - Beams dynamically balanced as per ISO rule 1940 Quality 6.3.

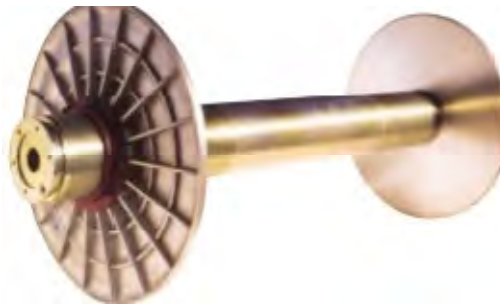

Ferber® and Ferber Textile Solutions ®

Sono marchi registrati di:/ are registered Trade Marks owned by: / sont des marques déposées appartenant à: sind eingetragene Warenzeichen von Besitz; /
يتم تسجيل العلامات التجارية التي تملكها
son marcas registradas propiedad de: / Marcas registadas de propriedade da / Her hakkı mahfuzdur / являются зарегистрированными товарными знаками,
принадлежащими компании;

GIOBBE S.r.l., Via Primo Maggio, 33 - 23873 Missaglia – Italy P.IVA-VAT 01665640130

WEB sites:

www.giobbeautomation.com www.ferber.it In USA see also- www.langligon.com/products.html

email: info@giobbeautomation.com vermarktung@ferber.it

Technical Assistance: ferberassistenza@giobbeautomation.com



Associato a Confindustria Lecco



*Attività fondata nel 1840 dall'artiere
fondatore Giovanni Beretta
e condotta senza interruzione dai
discendenti*



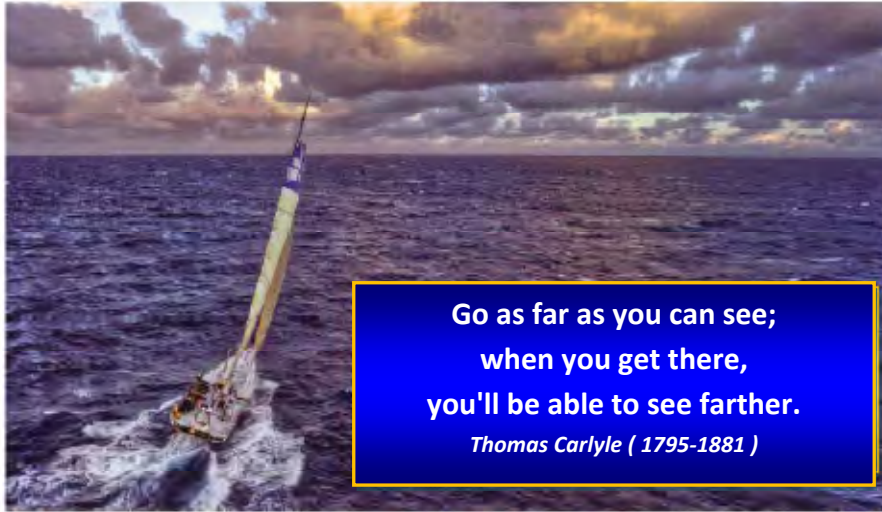

Go as far as you can see;
when you get there,
you'll be able to see farther.
Thomas Carlyle (1795-1881)

